



# TUBE ADAPTER 4I56

## TUBE ADAPTER

### TUBE ADAPTER

stainless steel

Stainless steel tube adapter. They are used exclusively for the manufacturing of lower extremity prostheses.

Made of high resistance stainless steel and indicated for patients with a maximum weight of 100 kg.

Tube adapter with 30 mm diameter and an inclination of 10° to be used in combination with screw adapter tubes as an adjustment device for modular leg prostheses.

These combinations provide angle and translation modifications in the sagittal and anterior plane, as well as regulation of internal and external rotation.



ACTIVITY LEVEL



PATIENT WEIGHT LIMIT



IMPACT LEVEL 1-2

RESISTANCE

100 KG

SKU

4I56

UNIT WEIGHT

133 GR

### CAUTION! ⚠

Do not expose the prosthetic components to environments that favor the corrosion of metal, as well as the degradation of the elements that make up the adapter. If it is exposed to any of these environments and the adapter has traces of elements that favors its deterioration, the warranty offered by O and P will be lost.

### WARRANTY

The 4I56 adapter warranty only applies if it is used under the conditions described in this sheet. This product is insured for 1 year using exclusively O and P modular products.

## TUBE ADAPTER

# INSTRUCTIONS FOR USE

The 4I56 adapter has a height of 4.25 cm.

Please follow the instructions below to avoid tube deformation. O and P tube tolerances are of approximately .001.

A deformed tube cannot be inserted into a tube adapter (4I56) without further difficulties.

### CAUTION!

Do not clamp the tube in the workbench screw, as this action can cause deformations or damage. The cut must form a 90° angle with respect to the outer wall line of the tube in the distal direction. The use of tube cutters (not saws) is recommended.

To install the tube, loosen the M4 x 22 mm screw <sup>1.1</sup> from the adapter (4I56), and insert the tube into it until it stops. <sup>1.2</sup>

### WARNING

For the definitive use of the M4 x 22 mm screw, secure it with a torque wrench set to 13 NM. The application of Loctite 242 threadlocker is necessary. Failure to follow this warning could result in the screw stripping and becoming unusable, as well as loosening over time.

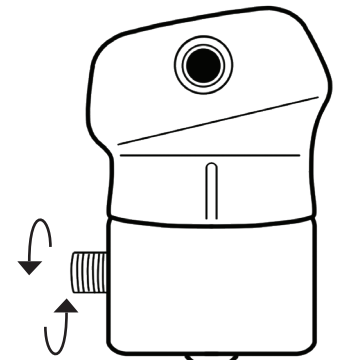

1.1

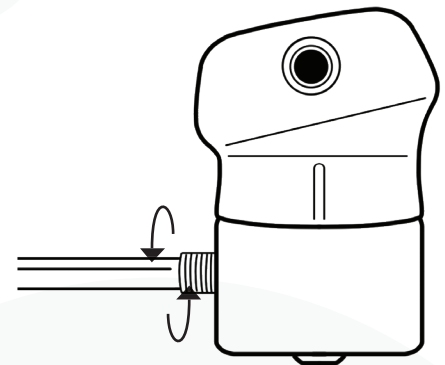

1.2

# TUBE ADAPTER INSTRUCTIONS FOR USE

The union with the opposite piece<sup>2</sup> in the modular system is through the M8 x 14 mm opposers.

Corrections can be made at any time during alignment, try-in and after completion of the prosthesis. To exchange any part, disassemble it. To keep the previous alignment, unscrew only the two adjoining opposers.

For the definitive use, secure it with a torque wrench set to 15 NM. The application of Loctite 242 threadlocker is necessary.



<b>ACTIVITY LEVEL</b>				
<b>PATIENT WEIGHT LIMIT</b>				
<b>IMPACT LEVEL</b>	1-2	<b>RESISTANCE</b>	100 KG	
<b>SKU</b>	4156	<b>UNIT WEIGHT</b>	133 GR	

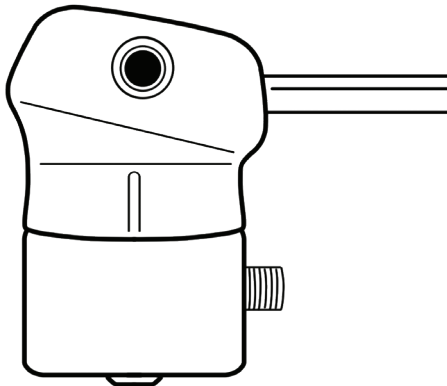
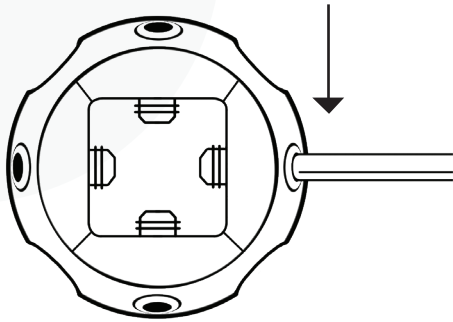

2