

# KNEE JOINT 3A13 MODULAR KNEE JOINT

## MODULAR KNEE JOINT

aluminum

Modular knee joint with pneumatic swing phase control 3A13.

Made of high resistance aluminum. Indicated for patients with a maximum weight of 100 kg.

This 4-bar knee joint is exclusively intended for the prosthetic fitting of transfemoral amputees with mobility grade 2-3.

Due to the polycentric technology, an especially large flexion angle is achieved. Additionally, the alignment of the multiple axes provides a shortening of the prosthetic leg during the swing phase, enhancing safety against tripping.

The pneumatic control of the swing phase in combination with the dynamic performance of the joint ensures a harmonious and natural gait pattern for the prosthesis wearer.



ACTIVITY LEVEL



PATIENT WEIGHT LIMIT



IMPACT LEVEL 2-3

RESISTANCE

100 KG

SKU 3A13

UNIT WEIGHT

905 GR

## CAUTION!

Do not expose the prosthetic components to environments that favor the corrosion of metal, as well as the degradation of the elements that make up the knee joint. If it is exposed to any of these environments and the joint has traces of elements that favors its deterioration, the warranty offered by O and P will be lost.

## WARRANTY

The 3A13 modular knee warranty only applies if it is used under the conditions described in this sheet. This product is insured for 1 year using exclusively O and P modular products.

# MODULAR KNEE JOINT

## INSTRUCTIONS FOR USE

Pneumatic polycentric knee joint with individually adjustable swing phase. Flexion and extension resistance can be adjusted separately.

The connection to proximal is effected by the male pyramid adaptors. Connection to distal is effected by the clamping of the lower part of the joint, into which the tube adapter is inserted.

According to the patients weight and movement, modify the flexion/extension control screw on the valve of the pneumatic 4-bar knee joint to increase/reduce the velocity for joint bending or stretching.

Flexion (F): Turn clockwise (right) for more flexion resistance.

Extension (E): Turn clockwise (right) for more extension resistance.







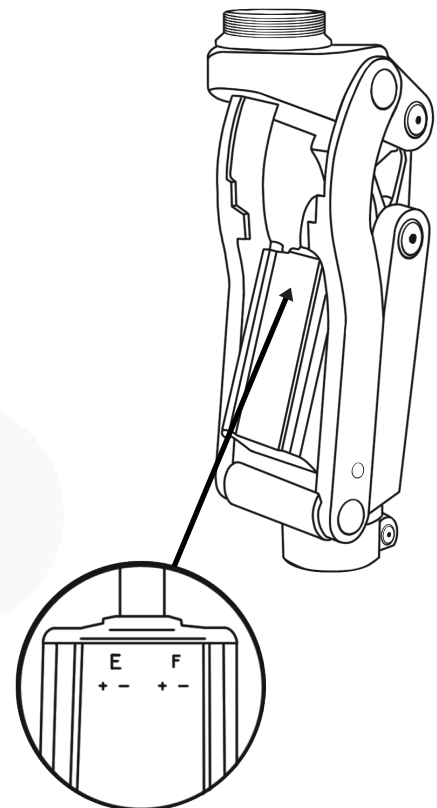

### CAUTION!

Do not clamp the tube into the workbench vice, as this action can cause deformations or damage.

### WARNING

Tighten the fillister head cap screw (16) for the tube clamping with Torque Wrench 10W495-1. Torque: 13 NM.



<b>ACTIVITY LEVEL</b>	   		
<b>PATIENT WEIGHT LIMIT</b>	   		
<b>IMPACT LEVEL</b>	2-3	<b>RESISTANCE</b>	100 KG
<b>SKU</b>	3A13	<b>UNIT WEIGHT</b>	905 GR